

Microtronix HDMI Receiver / Transmitter HSMC Daughter Card

USER MANUAL
REVISION 1.1



9-1510 Woodcock St.
London, ON
Canada N5H 5S1
www.microtronix.com



Document Revision History

This user guide provides basic information about using the **Microtronix HDMI Receiver / Transmitter HSMC Daughter Card**. The following table shows the document revision history.

Date	Rev	Description
June 2008	1.0	First release
July 2008	1.1	Addition of reference design

How to Contact Microtronix

E-mail

Sales Information: sales@microtronix.com

Support Information: support@microtronix.com

Website

Software updates to the **HDMI Receiver / Transmitter HSMC Daughter Card** and supporting Microtronix IP Cores are listed on the download page of our website and made available via an email request form. Some product upgrades are only available to customers who have purchased the ViClaro III kit.

The upload site is for sending files to Technical Support.

General Website: <http://www.microtronix.com>

Downloads Page: <http://www.microtronix.com/downloads/>

FTP Upload Site: <http://microtronix.leapfile.com>

Phone Numbers

General: (001) 519-690-0091

Fax: (001) 519-690-0092

Typographic Conventions

Path/Filename	A path/filename
[SOPC Builder]\$ <cmd>	A command that should be run from within the Cygwin Environment.
Code	Sample code.
↵	Indicates that there is no break between the current line and the next line.

Table of Contents

Document Revision History	2
How to Contact Microtronix	2
E-mail	2
Website	2
Phone Numbers	2
Typographic Conventions.....	2
Introduction	4
Kit Contents	4
Overview.....	5
Power Supply.....	5
Power Consumption	5
Introduction to HDMI Interfaces.....	5
EDID Interface	6
HDMI Connector Pin Assignments.....	7
HDMI Rx / TX Card Components	7
User LED	7
SW1 DIP Switches	8
Potentiometer VR1	8
EDID Serial EEPROM	8
HDCP Serial EEPROMs.....	8
I ² C 2-Wire Serial Bus.....	9
YPbPr Component Video Connectors.....	9
HSMC Connector J1	9
HDMI Rx / Tx Daughter Card Software Installation.....	12
Overview of HDMI Reference Design.....	12
Microtronix I ² C IP Core.....	13

Introduction

The Microtronix **HDMI Receiver / Transmitter HSMC Daughter Card** is targeted at the development of HD video systems incorporating a HDMI receiver or transmitter port. It is designed to interface an HDMI receiver and transmitter to an Altera FPGA Development Kit using the HSMC expansion connector. The card also provides an analog component (YPbPr) input.

The key features of the board include:

- Analog Devices AD9880 - Analog/HDMI Dual Display Receiver Interface,
 - HDMI v1.1, DVI v1.0 receiver
 - Analog YPbPr Video Receiver
- Analog Devices AD9889B– HDMI/DVI Transmitter Interface
 - HDMI v1.1 transmitter
- Reference design
- High bandwidth digital content protection (HDCP) support
- EDID data reading / writing via host board FPGA
- Altera compatible HSMC expansion connector

Kit Contents

The Microtronix **HDMI Receiver / Transmitter HSMC Daughter Card** is includes the following hardware components:

- HDMI Receiver / Transmitter HSMC Daughter Card (PN: 6256-20-00)
 - Card mounting hardware
- Microtronix HDMI Receiver / Transmitter HSMC Daughter Card – Installation CD
NOTE: The CD is not supplied when the HDMI card is purchased in conjunction with Microtronix ViClaro III Development Kit.

Overview

The Microtronix **HDMI Receiver / Transmitter (Rx/Tx) HSMC Daughter Card** uses the Analog Device AD9889BHDMI v1.1 transmitter to support HDTV formats up to 1080p at 60 Hz. Using a 165 MHz, high-definition multimedia interface (HDMI 1.1) transmitter. With the addition of a HDCP encryption key, the AD9889 allows the secure transmission of protected content as specified by the HDCP 1.1 protocol.

The AD9880 HDMI Receiver offers designers the flexibility of an analog interface and digital high definition multimedia interface (HDMI) v1.1 receiver integrated on a single chip. The receiver supports resolutions up to 1080p at 60 Hz.

The cards can support high bandwidth digital content protection (HDCP) when programmed with an HDCP encryption key.

A picture of the **HDMI Receiver / Transmitter HSMC Daughter Card** is shown below.

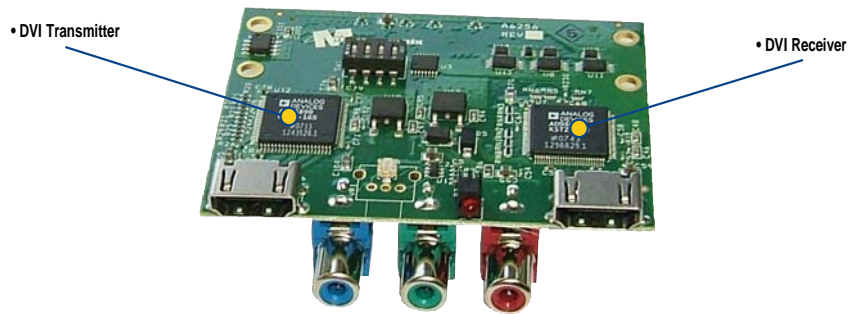

Figure 1: HDMI Receiver / Transmitter Daughter Card

Power Supply

The card operates from 3.3 VDC and 12.0 VDC supplied from the HSMC connector.

Power Consumption

The HDMI Rx / Tx board draws approximately 1A at 3.3 VDC and 75mA at 12.0 VDC. Power consumption varies according to the receive and transmit video resolution.

Introduction to HDMI Interfaces

The **High-Definition Multimedia Interface (HDMI)** is a compact connector interface for transmitting uncompressed digital video/audio streams. It is widely used across a broad range of consumer devices including: set-top TV boxes, Blu-ray Disk players, personal computers, televisions, and AV receivers.

The interface uses a Transition Minimized Differential Signaling (TMDS)-based protocol and electrical signaling

The HDMI cable and connectors carry four differential pairs that make up the TMDS data and clock channels. These channels are used to carry video, audio and auxiliary data. In addition, HDMI carries a VESA DDC channel. The DDC is used for configuration and status exchange between a single Source and a single Sink. The optional CEC protocol provides high-level control functions between all of the various audiovisual products in a user's. This feature is not supported on the card,

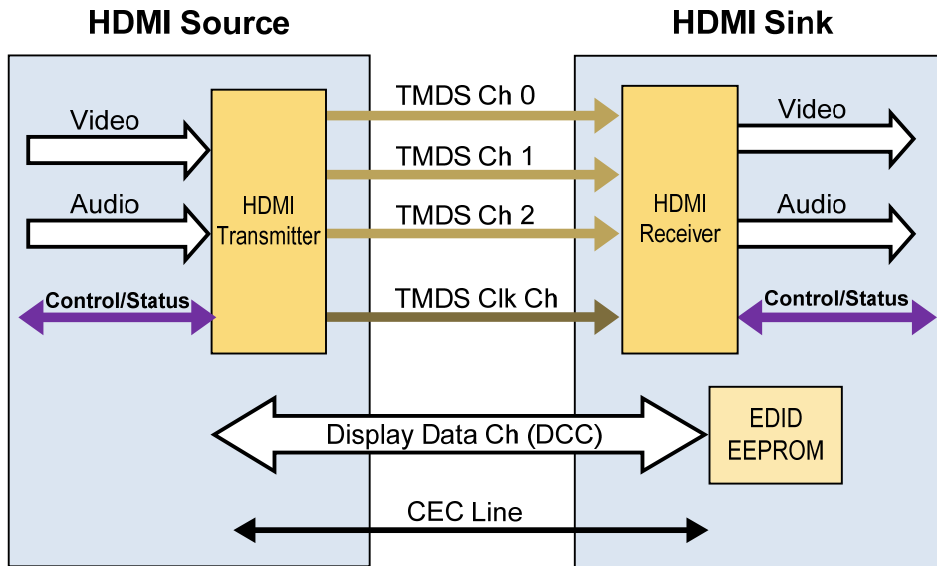

Figure 2: HDMI System Architecture

EDID Interface

Extended display identification data (EDID) is a data structure provided by a display panel to describe its capabilities to a graphics card. EDID is defined by a standard published by the Video Electronics Standards Association (VESA). The EDID includes manufacturer name, product type, phosphor or filter type, timings supported by the display, display size, luminance data and (for digital displays only) pixel mapping data.

EDID functionality is included on the HSMC HDMI card. On the receiver side, the HDMI card is equipped with an EEPROM device containing the EDID description data. This device can be read by the connected transmitter. There is also provision to change the contents of the EDID EEPROM. This is done using an I2C interface programmed into the FPGA on the host card. An example of how to change the EDID data is included with the card. It must be noted that writing to the EDID with

an external transmitter is not advised. This may cause data corruption or even damage to the HDMI card.

HDMI Connector Pin Assignments

The card incorporates a Type A connector which has 19 pins. The pin assignment is shown in the following table.

Table 1: HDMI Type A Connector Pin Assignment

Pin	Signal Name	Pin	Signal Name
1	TMDS Data2+	2	TMDS Data2 Shield
3	TMDS Data2+	4	TMDS Data1+
5	TMDS Data1 Shield	6	TMDS Data1+
7	TMDS Data0+	8	TMDS Data0 Shield
9	TMDS Data0+	10	TMDS Clock+
11	TMDS Clock Shield	12	TMDS Clock-
13	CEC	14	Reserved (N.C.)
15	SCL	16	SDA
17	DDC/CEC Ground	18	+5V Power
19	Hot Plug Detect		

HDMI Rx / TX Card Components

The Microtronix **HDMI Receiver / Transmitter HSMC Daughter Card** incorporates the following components and devices:

- Analog Devices AD9880 - Analog/HDMI Dual Display Receiver Interface,
- Analog Devices AD9889B – HDMI/DVI Transmitter Interface
- Atmel AT24C04A – Two-wire Serial EEPROM
- NXP PCA9554A – 8-bit I²C-bus I/O Port
- Misc:
 - Potentiometer
 - LED
 - 4-position DIP switch

For more information on the IC components, contact the respective vendors.

User LED

There one general-purpose LED (labeled D5). It connects to pin 131 of the HSMC connector.

SW1 DIP Switches

There is one general-purpose 4-position DIP switch labeled SW1. It is interfaced via an 8-bit I²C-bus I/O Port (NXP PCA954A). There is a conflict between the I²C address of this device and one of the configuration pages of the HDMI transmitter. Register 0xCF of I²C device 0x72 controls the address used by the conflicting page of the transmitter. It must be written with a non-conflicting value (such as 0x56) before attempting to access the I/O Port device.

Table 2: SW1 DIP Switch – I/O Port Assignments

Switch	Port Number
SW1-1	I/O0
SW1-2	I/O1
SW1-3	I/O2
SW1-4	I/O3

Potentiometer VR1

There is one general-purpose potentiometer labeled VR1. It is interfaced via an ADC081S021 8-bit A/D Converter with SPI interface.

Table 3: POT ADC pin assignments

Switch	HSMC Pin Number
ADC_SCLK	73
ADC_SDAT	67
ADC_CS#	71

EDID Serial EEPROM

The EDID information is stored in an Atmel AT24C04A, a two-wire Serial EEPROM device located at U8. It is connected to the common 2-wire I²C serial port via an NLAS2066 Analog Switch.

HDCP Serial EEPROMs

The HDCP information is stored in Atmel AT24C04A, 2-wire Serial EEPROM devices located at U10 and U11. They are connected to the common 2-wire I²C serial port of the HSMC connector via two NLAS2066 Analog Switches. Note that HDCP keys are not included with the board.

I²C 2-Wire Serial Bus

The HDMI Rx/TX card contains one I²C Bus. The SDA and SCL bus signals are connected to the assigned pins (33 & 34) of the HSMC connector. The user can access I²C connected devices from a Host board using a Microtronix I²C Master IP Core programmed into the FPGA device.

Table 4: I²C Addresses

Device	I ² C Address
AD9880	0x98
AD9889B	0x72
PCA9554A	0x70

YPbPr Component Video Connectors

The HDMI Rx/Tx card provides an analog YPbPr component video interface. It supports a 150 MSPS encode rate capability and full power analog bandwidth of 330 MHz, and supports all HDTV formats up to 1080p.

HSMC Connector J1

The HSMC Connector, J1 interfaces the **HDMI Rx/Tx HSMC Daughter Card** to the Host board. The pin assignments are shown below. The ViClaro III FPGA pin assignments apply when the HDMI board is installed on HMSC Header J4, (the LVDS header).

Table 5: HSMC Connector J1, pin assignments

ViClaro III Cyclone III Pin #	Signal Name	HSMC Pin #	HSMC Pin #	Signal Name	ViClaro III Cyclone III Pin #
	NC	1	2	NC	
	NC	3	4	NC	
	NC	5	6	NC	
	NC	7	8	NC	
AE3	NC	9	10	NC	AE2
AF2	NC	11	12	NC	AE1

AC3	NC	13	14	NC	AD2
AD3	NC	15	16	NC	AD1
AC5	NC	17	18	NC	AC2
AC4	NC	19	20	NC	AC1
AB6	NC	21	22	NC	AB2
AB5	NC	23	24	NC	AB1
AA6	NC	25	26	NC	AA4
AA5	NC	27	28	NC	AA3
Y6	NC	29	30	NC	Y4
Y5	NC	31	32	NC	Y3
Y10	I2C_SDA	33	34	I2C_SCL	AA10
	NC	35	36	NC	
	NC	37	38	NC	
	NC	39	40	NC	
T8	VIDEO_IN_FIELD	41	42	VIDEO_IN_G0	T7
M5	VIDEO_IN_B0	43	44	VIDEO_IN_G1	L5
	3.3V	45	46	12V	
W8	VIDEO_IN_B1	47	48	VIDEO_IN_G2	W2
Y7	VIDEO_IN_B2	49	50	VIDEO_IN_G3	W1
	3.3V	51	52	12V	
V8	VIDEO_IN_B3	53	54	VIDEO_IN_G4	W4
V7	VIDEO_IN_B4	55	56	VIDEO_IN_G5	W3
	3.3V	57	58	12V	
V6	VIDEO_IN_B5	59	60	VIDEO_IN_G6	V4
V5	VIDEO_IN_B6	61	62	VIDEO_IN_G7	V3
	3.3V	63	64	12V	
U6	VIDEO_IN_B7	65	66	VIDEO_IN_R0	V2
U5	ADC_SDAT	67	68	VIDEO_IN_R1	V1
	3.3V	69	70	12V	
R7	ADC_CS#	71	72	VIDEO_IN_R2	U2
R6	ADC_SCLK	73	74	VIDEO_IN_R3	U1
	3.3V	75	76	12V	
M8	VIDEO_IN_DE	77	78	VIDEO_IN_R4	U3
M7	VIDEO_IN_VS	79	80	VIDEO_IN_R5	U4
	3.3V	81	82	12V	

K8	VIDEO_IN_HS	83	84	VIDEO_IN_R6	T4
L8	VIDEO_IN_SPDIF	85	86	VIDEO_IN_R7	T3
	3.3V	87	88	12V	
J7	VIDEO_OUT_R7	89	90	VIDEO_INMCLK	R2
K7	VIDEO_OUT_R6	91	92	VIDEO_IN_SCLK	R1
	3.3V	93	94	12V	
R3	VIDEO_OUT_CLK	95	96	VIDEO_IN_CLK	Y2
R4	VIDEO_IN_I2S)	97	98		Y1
	3.3V	99	100	12V	
M4	VIDEO_OUT_R5	101	102	VIDEO_OUT_R3	L4
M3	VIDEO_OUT_R4	103	104	VIDEO_OUT_R2	L3
	3.3V	105	106	12V	
P2	VIDEO_RX_HDCP_EN	107	108	VIDEO_OUT_R1	L2
P1	VIDEO_RX_EDID_EN	109	110	VIDEO_OUT_R0	L1
	3.3V	111	112	12V	
N4	VIDEO_IN_LRCLK	113	114	VIDEO_OUT_G7	K4
N3	VIDEO_OUT_DE	115	116	VIDEO_OUT_G6	K3
	3.3V	117	118	12V	
L7	VIDEO_OUT_HS	119	120	VIDEO_OUT_G5	K2
L6	VIDEO_OUT_VS	121	122	VIDEO_OUT_G4	K1
	3.3V	123	124	12V	
J6	VIDEO_IN_I2S2	125	126	VIDEO_OUT_G3	J4
J5	VIDEO_IN_I2S1	127	128	VIDEO_OUT_G2	J3
	3.3V	129	130	12V	
M2	LED_ON	131	132	VIDEO_OUT_G1	H4
M1	VIDEO_OUT_HDCP_EN	133	134	VIDEO_OUT_G0	H3
	3.3V	135	136	12V	
G6	VIDEO_OUT_I2S1	137	138	VIDEO_OUT_B7	G2
G5	VIDEO_OUT_I2S0	139	140	VIDEO_OUT_B6	G1
	3.3V	141	142	12V	
G4	VIDEO_OUT_MCLK	143	144	VIDEO_OUT_B5	F2
G3	VIDEO_OUT_ISCLK	145	146	VIDEO_OUT_B4	F1
	3.3V	147	148	12V	

D2	VIDEO_OUT_B1	149	150	VIDEO_OUT_B3	E3
D1	VIDEO_OUT_B0	151	152	VIDEO_OUT_B2	F3
	3.3V	153	154	12V	
D3	VIDEO_OUT_LRCLK	155	156		J2
C2	VIDEO_OUT_SPDIF	157	158	VIDEO_TX_INT	J1
	3.3V	159	160	Presence LED	

HDMI Rx / Tx Daughter Card Software Installation

NOTE: This section only applies if the **HDMI Rx / Tx HSMC Daughter Card** was purchased as a stand-alone board. When the card is purchased in conjunction with the Microtronix ViClaro III HD Video IP Development Kit, the HDMI reference designs are supplied as part off the ViClaro III Software Installation CD.

The HDMI Card software is supplied by Microtronix on a CD or via FTP as a zipped file. If you received the latter, unzip the file to a temporary file directory and run the setup.exe file. The software should self-install from the CD or it can be manually installed by running the setup.exe file.

WARNING: Remove older installations of the HDMI Card software from the PC prior to installing the new version of software.

Overview of HDMI Reference Design

The HDMI Card is supplied with a basic reference design for the Altera Cyclone III Starter Kit. It includes a pre-compiled SOF file and the Quartus II 8.0 project files. The design loops or passes through the HDMI digital input video direct to the HDMI output. A Nios II and the Microtronix Avalon I2C Controller is used to configure the HDMI devices. The design also enables the user to program the EDID to match the video resolution of the display monitor.

Table 6: Quartus Reference Designs

Name / Description	Directory & Filename
HDMI pass-through	example/hsmc_hdmi/: mtx_hdmi.sof
EDID Programming for 60 Hz	example/hsmc_hdmi/: mtx_hdmi_EDID_60.sof
EDID Programming for 50 Hz	example/hsmc_hdmi/: mtx_hdmi_EDID_50.sof

Source code for the Nios II software can be found in example/hsmc_hdmi/software. The two software projects,

mtx_hdmi_syslib and mtx_hdmi can be imported into the Nios II IDE with the following procedure.

1. Selecting “Import...” from the “File” menu.
2. Choose “Altera Nios II” and “Existing Nios II IDE project into workspace” as the import source then click “Next”.
3. Browse to the mtx_hdmi_syslib project and click “OK”
4. Ensure that the nios.ptf file from the example project is selected as the “SOPC Builder System PTF File”. If not, browse to it and click “Open”, next select “cpu” from the “CPU” drop-down list.
5. Click “Finish” to import the project.
6. Repeat process for the mtx_hdmi project.

The software includes examples of reading the potentiometer ADC and the switches state.

Microtronix I²C IP Core

The reference design(s) incorporate the ***Microtronix I²C Master / Slave / PIO Controller IP Core***. This core is used in conjunction with an Nios II soft-core processor to initialize and configure the Analog Devices Receiver and Transmitter components and to program EDID EEPROM.

A 60-day OpenCores Plus licenses is available for testing your custom design in-circuit limited time period. (Refer to the Altera website for more information.)

To receive your IP core license contact sales, sales@microtronix.com and provide them with the serial number of your board and either your NIC or GUARD ID. This license is required for you to recompile and test in-circuit new IP core designs.